



Fieros and LED bulbs

Topics

- Led basics
- Interior bulbs
- Exterior bulbs
- Flashing bulbs

Trade Number	Watts	Amps	Locations
1156	21W	2.1	Back Up, Fastback RR Turn signal
2057	5/21W	0.48/2.1	FT Park/Turn signal, Tail/Stop, Notchback Tail/Turn signal
906	?		Dome Light
889	?		Center Mounted Stop Light
561	?		Rear luggage compartment
194	3W	0.27	License, Side markers, Cluster illumination, Telltale lights
168	5W	0.35	IP Courtesy, Front luggage compartment
70	1W		Ash Tray lights
37	?		A/C Control, Heater Control

basics

Basic LED Reference Example

Kelvin Color Temperature Scale Chart

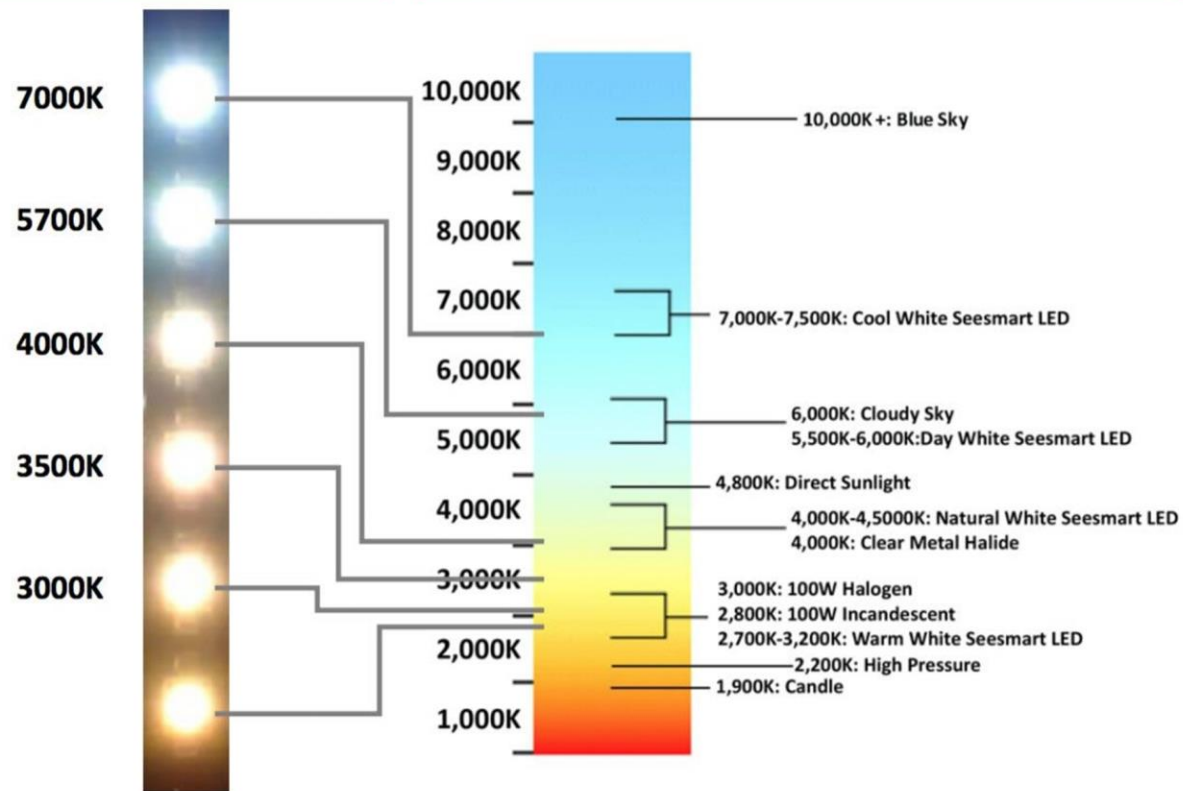

Basics continued

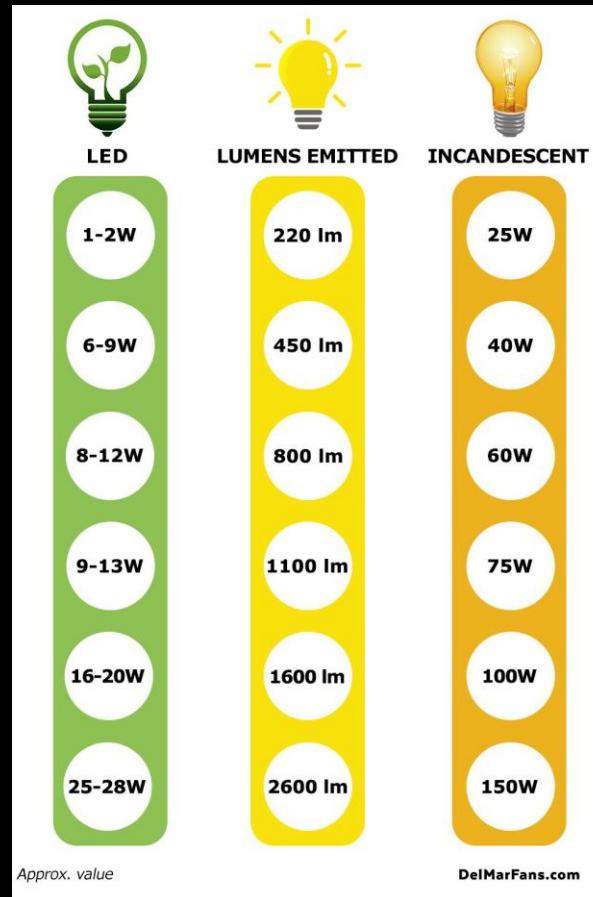

Basics continued

- Heat dissipation
 - Cheap none
 - Moderate small heat sync pricy but still hot
 - Expensive has fan but wont fit in to the housing anymore due to size change

Basics continued

- Connector version wire vs actual circuit board connection.

Left hand side is cheap and will fail in time

Right hand side is large and sometimes wont fit in the bulb socket

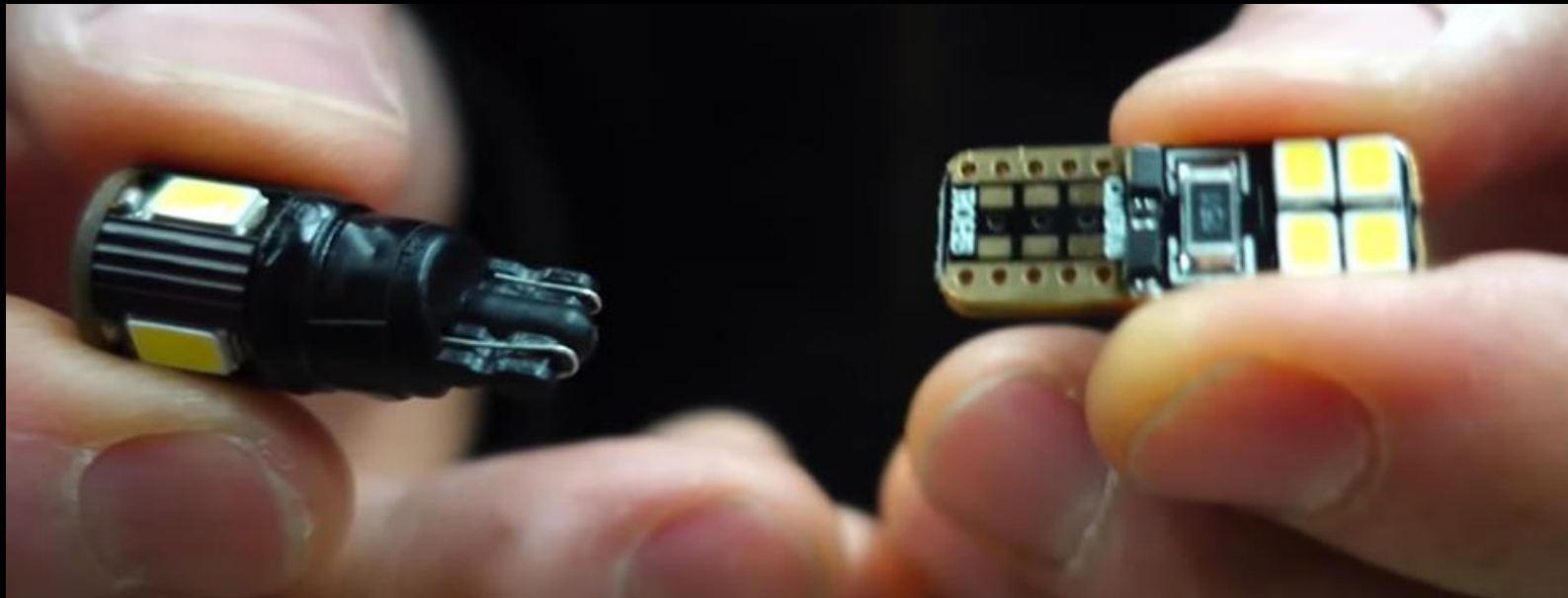

Fiero interior bulbs

- All interior bulbs are easily swappable
- Watch running temperature it can melt the housing



Trade Number	Watts	Amps	Locations
1156	21W	2.1	Back Up, Fastback RR Turn signal
2057	5/21W	0.48/2.1	FT Park/Turn signal, Tail/Stop, Notchback Tail/Turn signal
906	?		Dome Light
889	?		Center Mounted Stop Light
561	?		Rear luggage compartment
194	3W	0.27	License, Side markers, Cluster illumination, Telltale lights
168	5W	0.35	IP Courtesy, Front luggage compartment
70	1W		Ash Tray lights
37	?		A/C Control, Heater Control

Bulb sizes



** Note the differences!!! Also Led's don't always work in the fiero with difference in depth of the barrels for socket round barrel bulbs **

Side marker bulbs



Headlight conversions

- MUST BE DOT compliant!!!!!!
- If not and found in an accident depending on insurance, you could be fully liable for the event with no insurance to cover.



Front turn signal

- Switchback – not dot legal “depending on how it switches back and forth”



Taillights

- Flasher upgrade
- Bulb replacements
- Line bar replacements
- Sequential led setup

Flasher upgrade needed for led flashers

- differences between hazard and flasher relay do both

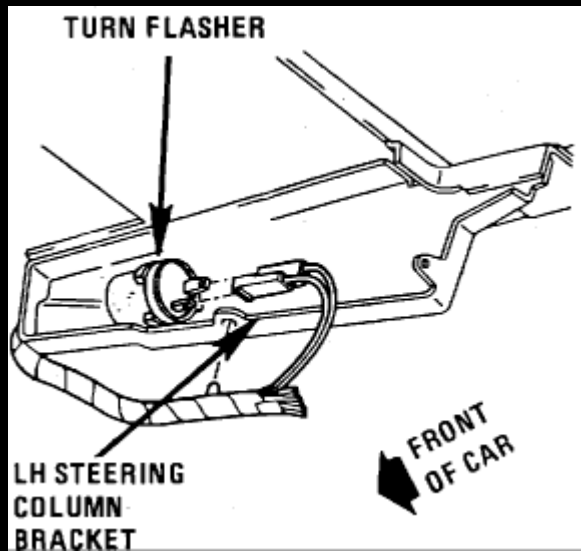

Tail light bulb



Light bars / full led replacements

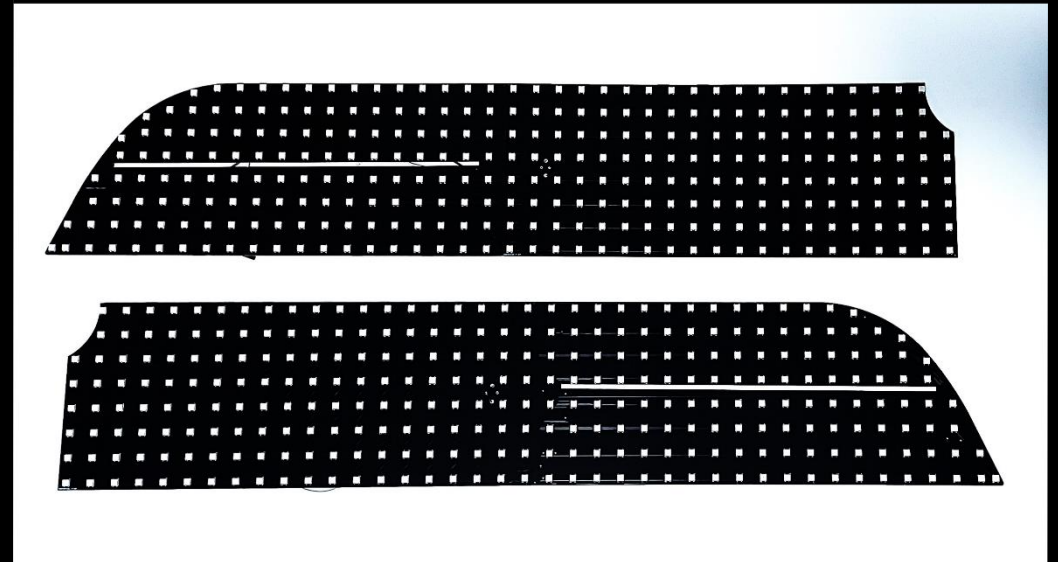

Sequential

- Different kits
 - Including brake light
 - Not including brake light
 - Flasher and sequential

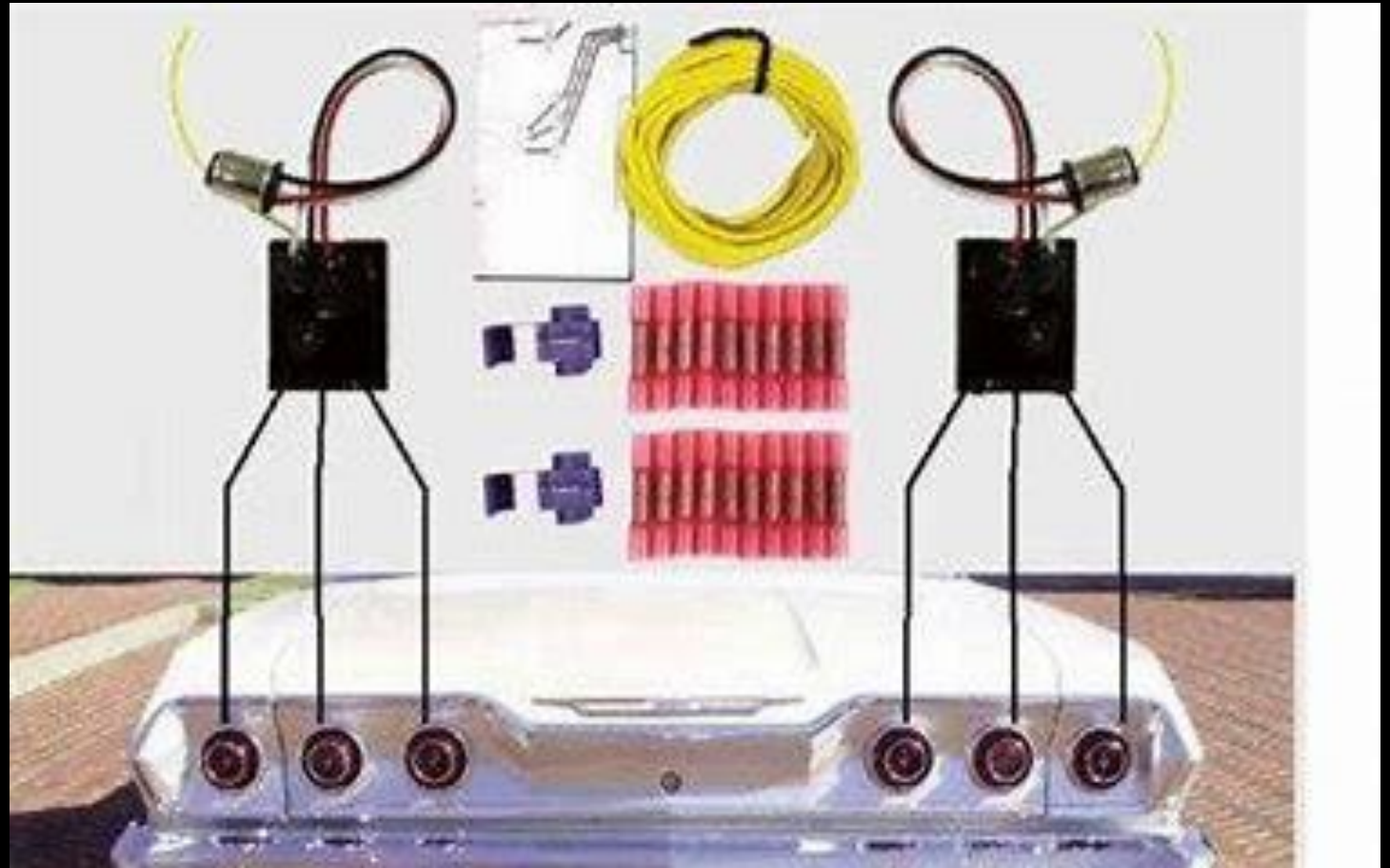

Questions?